

NOTES:

- 1) DO NOT SCALE THIS DRAWING.
- 2) UNLESS OTHERWISE SPECIFIED, SHARP EDGES AND CORNERS REMOVED. MAXIMUM 0.015 RADIUS.
- 3) UNLESS OTHERWISE SPECIFIED, ALL DIMENSIONS ARE AFTER PLATING.

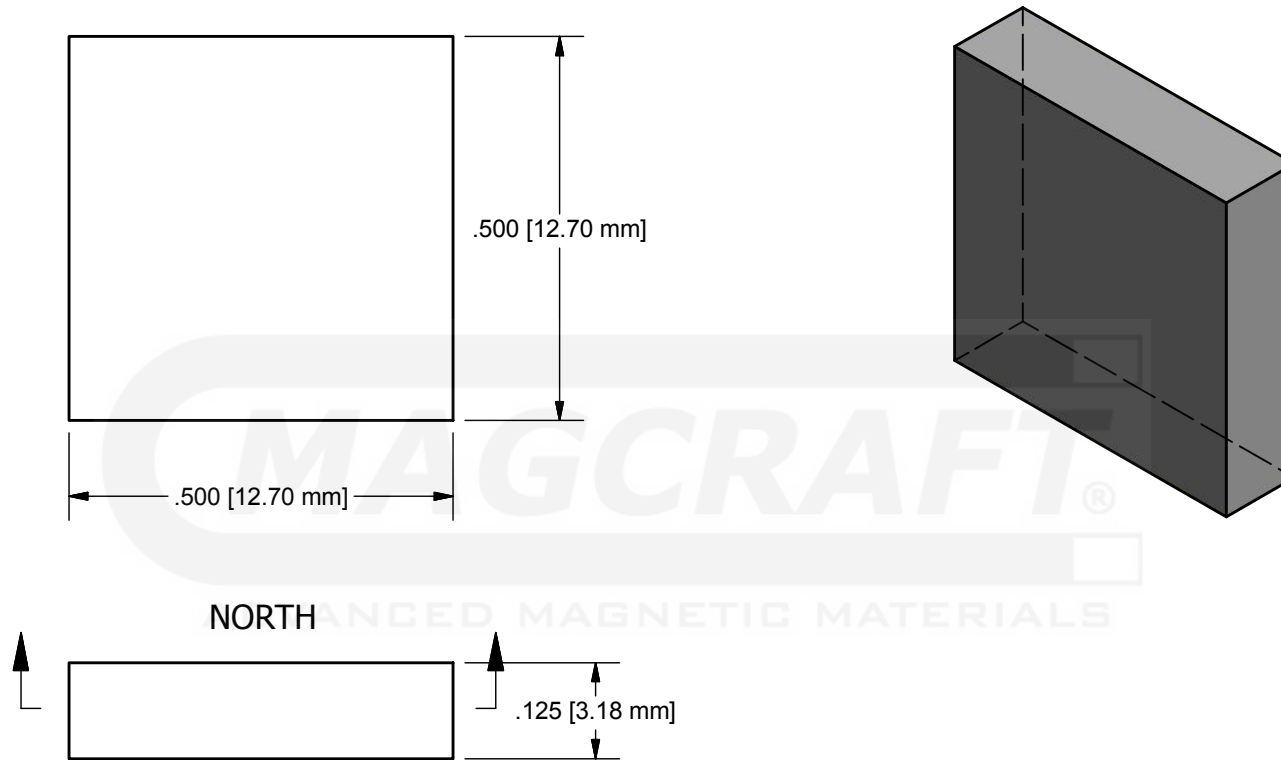

MFG APPROVED DATE: **12/19/2014**

UNLESS OTHERWISE SPECIFIED:
 DIMENSIONS ARE IN INCHES
 TOLERANCES:
 FRACTIONAL $\pm 1/64$
 ANGULAR $\pm 1^\circ$
 TWO PLACE DECIMAL ± 0.01
 THREE PLACE DECIMAL ± 0.005



TITLE:
MAGCRAFT PART NSN0011

MATERIAL: **MAGCRAFT ALLOY N40**

SIZE

DWG. NO.

REV

FINISH: **Ni-Cu-Ni PLATING**

A

NSN0011

0

CAD FILE: **NSN0011.dwg**

SCALE: **4 : 1**

SHEET **1** OF **1**